



JEST PHYSICS 2018

PART – A : ONE mark questions:

- A ball of mass m starting from rest, falls a vertical distance h before striking a vertical spring, which it compresses by a length δ . What is the spring constant of the spring? (Hint: Measure all the vertical distances from the point where the ball first touches the uncompressed spring i.e., set this point as the origin of the vertical axis)

(a) $\frac{2mg}{\delta^2}(h + \delta)$ (b) $\frac{2mgh}{\delta^3}(h - \delta)$ (c) $\frac{2mg}{\delta^2}(h - \delta)$ (d) $\frac{2mg}{\delta^2}h$
- An electromagnetic wave of wavelength λ is incident normally on a dielectric slab of thickness t . If K is the dielectric constant of the slab, the change in phase of the emergent wave compared with the case of propagation in the absence of the dielectric slab is

(a) $\sqrt{K} - 1$ (b) 2π (c) $\frac{2\pi t}{\lambda}$ (d) $\frac{2\pi t}{\lambda}(\sqrt{K} - 1)$
- If (q, p) is a canonically conjugate pair, which of the following is not a canonically conjugate pair?

(a) $(q^2, pq^{-1}/2)$ (b) $(p^2, -pq^{-1}/2)$ (c) $(pq^{-1}, -q^2)$

(d) $(f(p), -q/f'(p))$, where $f'(p)$ is the derivative of $f(p)$
- A Germanium diode is operated at a temperature of 27 degree C. The diode terminal voltage is 0.3V when the forward current is 10 mA. What is the forward current (in mA) if the terminal voltage is 0.4V?

(a) 477.3 (b) 577.3 (c) 47.73 (d) 57.73
- When a collection of two-level systems is in equilibrium at temperature T_0 , the ratio of the population in the lower and upper levels is 2 : 1. When the temperature is changed to T , the ratio is 8 : 1. Then

(a) $T = 2T_0$ (b) $T_0 = 2T$ (c) $T_0 = 3T$ (d) $T_0 = 4T$
- A collection of N interacting magnetic moments, each of magnitude μ , is subjected to a magnetic field H along the z -direction. Each magnetic moment has a doubly degenerate level of energy zero, and two non-degenerate levels of energies $-\mu H$ and μH respectively. The collection is in thermal equilibrium at temperature T . The total energy $E(T, H)$ of the collection is

(a) $-\frac{\mu HN \sinh(\mu H / k_B T)}{1 + \cosh(\mu H / k_B T)}$ (b) $-\frac{\mu HN}{2(1 + \cosh(\mu H / k_B T))}$

(c) $-\frac{\mu HN \cosh(\mu H / k_B T)}{1 + \cosh(\mu H / k_B T)}$ (d) $-\mu HN \frac{\sinh(\mu H / k_B T)}{\cosh(\mu H / k_B T)}$
- For which of the following conditions does the integral $\int_0^1 P_m(x) P_n(x) dx$ vanish for $m \neq n$, where $P_m(x)$ and $P_n(x)$ are the Legendre polynomials of order m and n respectively?

(a) all $m, m \neq n$ (b) $m - n$ is an odd integer

(c) $m - n$ is a non-zero even integer (d) $n = m \pm 1$



8. A block of mass M is moving on a frictionless inclined surface of a wedge of mass m under the influence of gravity. The wedge is lying on a rigid frictionless horizontal surface. The configuration can be described using the radius vectors \vec{r}_1 and \vec{r}_2 shown in the figure. How many constraints are present and what are the types?

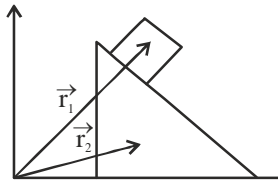

- (a) One constraint; holonomic and scleronomous
 (b) Two constraints; both are holonomic, one is scleronomous and rheonomous
 (c) Two constraints; both are scleronomous; one is holonomic and the other is non-holonomic
 (d) Two constraints; both are holonomic and scleronomous
9. Consider a particle of mass m moving under the effect of an attractive central potential given as $V = -kr^{-3}$, where $k > 0$. For a given angular momentum L , $r_0 = 3km / L^2$ corresponds to the radius of the possible circular orbit and the corresponding energy is $E_0 = L^2 / (6mr_0^2)$. The particle is released from $r > r_0$ with an inward velocity, energy $E = E_0$ and angular momentum L .
- (a) zero (b) $2mr_0^2 L^{-1}$ (c) $\sqrt{2}mr_0^2 L^{-1}$ (d) Infinite
10. A one dimensional harmonic oscillator (mass m and frequency ω) is in a state ψ such that the only possible outcomes of an energy measurement are E_0, E_1 or E_2 , where E_n is the energy of the n -th excited state. If H is the Hamiltonian of the oscillator, $\langle \psi | H | \psi \rangle = 3\hbar\omega / 2$ and $\langle \psi | H^2 | \psi \rangle = 11\hbar^2\omega^2 / 4$, then the probability that the energy measurement yields E_0 is
- (a) 1/2 (b) 1/4 (c) 1/8 (d) 0
11. What is the difference between the maximum and the minimum eigenvalues of a system of two electrons whose Hamiltonian is $H + J\vec{S}_1 \cdot \vec{S}_2$, where \vec{S}_1 and \vec{S}_2 are the corresponding spin angular momentum operators of the two electrons?
- (a) $J/4$ (b) $J/2$ (c) $3J/4$ (d) J
12. Two dielectric spheres of radius R are separated by a distance a such that $a \gg R$. One of the spheres (sphere 1) has a charge q and the other is neutral. If the linear dimensions of the systems are scaled up by a factor two, by what factor should the charge on the sphere 1 be changed so that the force between the two spheres remain unchanged?
- (a) 2 (b) $4\sqrt{2}$ (c) 4 (d) $2\sqrt{2}$
13. An electric charge distribution produces an electric field
- $$\vec{E} = (1 - e^{-\alpha r}) \frac{\vec{r}}{r^3}$$
- where δ and α are constants. The net charge within a sphere of radius α^{-1} centred at the origin is
- (a) $4\pi \epsilon_0 (1 - e^{-1})$ (b) $4\pi \epsilon_0 (1 + e^{-1})$ (c) $-4\pi \epsilon_0 \frac{1}{\alpha e}$ (d) $4\pi \epsilon_0 \frac{1}{\alpha e}$

14. The charge density as a function of the radial distance r is given by

$$\rho(r) = \rho_0 \frac{R^2 - r^2}{R^2}$$

for $r < R$ and zero otherwise. The electric flux over the surface of an ellipsoid with axes $3R$, $4R$ and $5R$ centred at the origin is

- (a) $\frac{4}{3\epsilon_0} \pi \rho_0 R^3$ (b) $\frac{8}{9\epsilon_0} \pi \rho_0 R^3$ (c) $\frac{8}{15\epsilon_0} \pi \rho_0 R^3$ (d) 0

15. If $\psi(x)$ is a infinitely differentiable function, then $\hat{D}\psi(x)$, where the operator $\hat{D} = \exp\left(ax \frac{d}{dx}\right)$, is

- (a) $\psi(x+a)$ (b) $\psi(ae^a + x)$ (c) $\psi(e^a x)$ (d) $e^a \psi(x)$

16. The Laplace transform of $(\sin(at) - at \cos(at)) / (2a^3)$ is

- (a) $\frac{2as}{(s^2 + a^2)^2}$ (b) $\frac{s^2 - a^2}{(s^2 + a^2)^2}$ (c) $\frac{1}{(s+a)^2}$ (d) $\frac{1}{(s^2 + a^2)^2}$

17. $\pi \int_{-\infty}^{\infty} \exp(-|x|) \delta(\sin(\pi x)) dx$, where $\delta(\dots)$ is Dirac delta distribution, is

- (a) 1 (b) $\frac{e+1}{e-1}$ (c) $\frac{e-1}{e+1}$ (d) $\frac{e}{e+1}$

18. The integral, $\int_{-\infty}^{\infty} \frac{\cos x}{x^2 + 1} dx$ is

- (a) $\frac{\pi}{e}$ (b) πe^{-2} (c) π (d) zero

19. Two of the eigenvalues of the matrix

$$A = \begin{pmatrix} a & 3 & 0 \\ 3 & 2 & 0 \\ 0 & 0 & 1 \end{pmatrix}$$

are 1 and -1 . What is the third eigenvalue?

- (a) 2 (b) 5 (c) -2 (d) -5

20. Consider two canonically conjugate operators \hat{X} and \hat{Y} such that $[\hat{X}, \hat{Y}] = i\hbar I$, where I is identity operator.

If $\hat{X} = \alpha_{11}\hat{Q}_1 + \alpha_{12}\hat{Q}_2$, $\hat{Y} = \alpha_{21}\hat{Q}_1 + \alpha_{22}\hat{Q}_2$, where α_{ij} are complex numbers, and $[\hat{Q}_1, \hat{Q}_2] = zI$, the value of $\alpha_{11}\alpha_{22} - \alpha_{12}\alpha_{21}$ is

- (a) $i\hbar z$ (b) $i\hbar / z$ (c) $i\hbar$ (d) z

21. A quantum particle of mass m is moving on a horizontal circular path of radius a . The particle is prepared in a quantum state described by the wavefunction,

$$\psi = \sqrt{\frac{4}{3\pi}} \cos^2 \phi$$

ϕ being the azimuthal angle. If a measurement of the z-component of orbital angular momentum of the particle is carried out, the possible outcomes and the corresponding probabilities are

(a) $L_z = 0, \pm \hbar, \pm 2\hbar$ with $P(0) = \frac{1}{5}$, $P(\pm\hbar) = \frac{1}{5}$ and $P(\pm 2\hbar) = \frac{1}{5}$

(b) $L_z = 0$ with $P(0) = 1$

(c) $L_z = 0, \pm \hbar$ with $P(0) = \frac{1}{3}$ and $P(\pm\hbar) = \frac{1}{3}$

(d) $L_z = 0, \pm 2\hbar$ with $P(0) = \frac{2}{3}$ and $P(\pm 2\hbar) = \frac{1}{6}$

22. Suppose the spin degree of freedom of two particles (non-zero rest and mass and non-zero spin) is described completely by a Hilbert space of dimension twenty one. Which of the following could be the spin of one of the particles?

- (a) 2 (b) 3/2 (c) 1 (d) 1/2

23. For a classical system of non-interacting particles in the presence of a spherically symmetric potential $V(r) = \gamma r^3$, what is the mean energy per particle? γ is a constant.

(a) $\frac{3}{2}k_B T$ (b) $\frac{5}{2}k_B T$ (c) $\frac{3}{2}\gamma k_B T$ (d) $\frac{3}{2}\gamma k_B T$

24. A particle of mass 1 kg is undergoing small oscillation about the equilibrium point in the potential

$V(x) = \frac{1}{2x^{12}} - \frac{1}{x^6}$ for $x > 0$ meters. The time period (in seconds) of the oscillation is

(a) $\frac{\pi}{2}$ (b) $\frac{\pi}{3}$ (c) 1.0 (d) π

25. In a thermodynamic process, the volume of one mole of an ideal is varied as $V = aT^{-1}$, where a is a constant. The adiabatic exponent of the gas is γ . What is the amount of heat received by the gas if the temperature of the gas increases ΔT in the process?

(a) $R\Delta T$ (b) $\frac{R\Delta T}{1-\gamma}$ (c) $\frac{R\Delta T}{2-\gamma}$ (d) $R\Delta T \frac{2-\gamma}{\gamma-1}$

PART – B : THREE marks questions:

1. In the circuit shown below, the capacitor is initially uncharged. Immediately after the key K is closed, the reading in the ammeter is 27 mA. What will the reading (in mA) be a long time later?

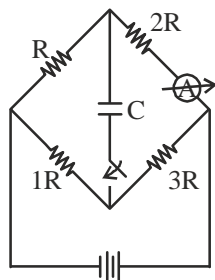

2. Two conductors are embedded in a material of conductivity 10^{-4} ohm-m and dielectric constant $\epsilon = 80 \epsilon_0$. The resistance between the two conductors is 10^6 ohm. What is the capacitance (in pF) between the conductors? Ignore the decimal part of the answer.
3. An electronic circuit with 10000 components performs its intended function successfully with a probability 0.99 if there are no faulty components in the circuit. The probability that there are faulty components is 0.05. If there are faulty components, the circuit perform successfully with a probability 0.3. The probability that the circuit performs successfully is $x/10000$. What is x ?
4. The normalized eigenfunctions and eigenvalues of the Hamiltonian of a particle confined to move between $0 \leq x \leq a$ in one dimension are

$$\psi_n(x) = \frac{2}{a} \sin \frac{n\pi x}{a}$$

and

$$E_n = \frac{n^2 \pi^2 \hbar^2}{2ma^2}$$

respectively. Here 1, 2, 3, Suppose the state of the particle is

$$\psi(x) = A \sin\left(\frac{\pi x}{a}\right) \left[1 + \cos\left(\frac{\pi x}{a}\right)\right]$$

where A is the normalization constant. If the energy of the particle is measured, the probability to get the result as $\frac{\pi^2 \hbar^2}{2ma^2}$ is $x/100$. What is the value of x ?

5. A harmonic oscillator has the following Hamiltonian

$$H_0 = \frac{\hat{p}^2}{2m} + \frac{1}{2} m\omega^2 \hat{x}^2$$

It is perturbed with a potential $V = \lambda \hat{x}^4$. Some of the matrix elements of \hat{x}^2 in terms of its expectation value in the ground state are given as follows:

$$\langle 0 | \hat{x}^2 | 0 \rangle = C ; \langle 0 | \hat{x}^2 | 2 \rangle = \sqrt{2}C ; \langle 1 | \hat{x}^2 | 1 \rangle = 3C ; \langle 1 | \hat{x}^2 | 3 \rangle = \sqrt{6}C$$

where $|n\rangle$ is the normalized eigenstate of H_0 corresponding to the eigenvalue $E_n = \hbar\omega(n + 1/2)$. Suppose ΔE_0 and ΔE_1 denote the energy correction of $O(\lambda)$ to the ground state and the first excited state, respectively. What is the fraction $\Delta E_1 / \Delta E_0$?

6. Consider the transistor circuit shown in the figure. Assume $V_{BEQ} = 0.7V$, $V_{BB} = 6V$ and the leakage current is negligible. What is the required value of R_B in kilo-ohms if the base current is to be $4 \mu A$?

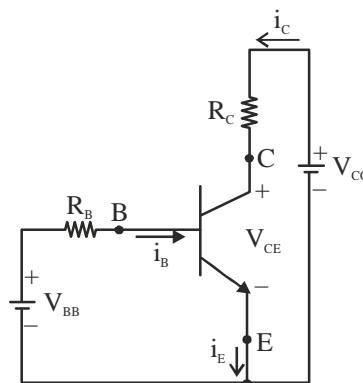

7. A person on Earth observes two rockets A and B directly approaching each other with speeds $0.8c$ and $0.6c$ respectively. At a time when the distance between the rockets is observed to be 4.2×10^8 m, the clocks of the rockets and the Earth are synchronized to $t = 0$ s. The time of collision (in seconds) of the two rockets as measured in rocket A's frame is $x/10$. What is x ?
8. If an abelian group is constructed with two distinct elements a and b such that $a^2 = b^2 = I$, where I is the group identity. What is the order of the smallest abelian group containing a , b and I ?
9. Two parallel rails of a railroad track are insulated from each other and from the ground. The distance between the rails is 1 meter. A voltmeter is electrically connected between the rails. Assume the vertical component of the earth's magnetic field to be 0.2 gauss. What is the voltage developed between the rails when a train travels at a speed of 180 km/h along the track? Give the answer in milli-volts.
10. Consider a simple pendulum in three-dimensional space. It consists of a string length $l = 20$ cm and bob mass $m = 15$ kg attached to it as shown in the figure below. The acceleration due to gravity is downwards as shown in the figure with a magnitude $g = 10 \text{ ms}^{-2}$.

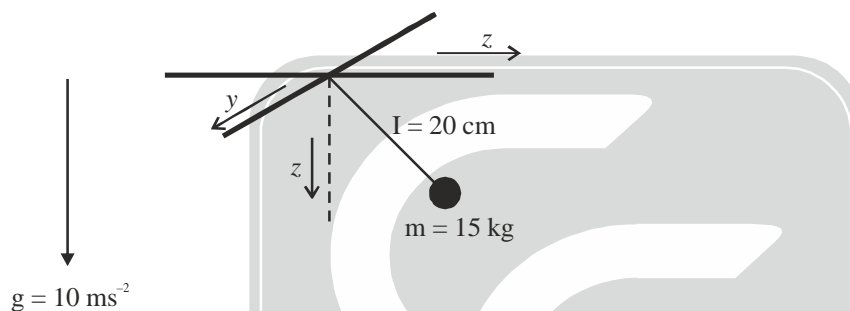

The pendulum is pulled in the $x-z$ plane to a position where the string makes an angle $\theta = \frac{\pi}{3}$ with the z -axis.

It is then released with an angular velocity Ω radians per second so that the angle the string makes with z -axis does not change with time?

PART – C : THREE marks questions:

1. A theoretical model for a real (non-ideal) gas gives the following expressions for the internal energy (U) and the pressure (P),

$$U(T, V) = aV^{-2/3} + bV^{2/3}T^2$$

$$\text{and } P(T, V) = \frac{2}{3}aV^{-5/3} + \frac{2}{3}bV^{-1/3}T^2$$

where a and b are constants. Let V_0 and T_0 be the initial volume and initial temperature respectively. If the gas expands adiabatically, the volume of the gas is proportional to

- (a) T (b) $T^{3/2}$ (c) $T^{-3/2}$ (d) T^{-2}

2. A frictionless, heat conducting piston of negligible mass and the heat capacity divides a vertical, insulated cylinder of height $2H$ and cross-sectional area A into two halves. Each half contains one mole of an ideal gas at temperature T_0 and pressure P_0 corresponding to STP. The heat capacity ratio $\gamma = C_p / C_v$ is given. A load of weight W is tied to the piston and suddenly released. After the system comes to equilibrium, the piston is at rest and the temperature of the gases in the two compartments are equal. What is the final displacement y of the piston from its initial, assuming $yW \gg T_0 C_v$?

- (a) $\frac{2H}{\sqrt{\gamma}}$ (b) $H\gamma$ (c) $\frac{H}{\sqrt{\gamma}}$ (d) $\frac{2H}{\gamma}$

3. An apparatus is made from two concentric conducting cylinders of radii a and b respectively, where $a < b$. The inner cylinder is grounded and the outer cylinder is at a positive potential V . The space between the cylinders has a uniform magnetic field H directed along the axis of the cylinders. Electrons leave the inner cylinder with zero speed and travel towards the outer cylinder. What is the threshold value of V below which the electrons cannot reach the outer cylinder?

- (a) $\frac{eH^2(b^2 - a^2)}{8mc^2}$ (b) $\frac{eH^2(b^2 - a^2)^2}{8mc^2b^2}$ (c) $\frac{eH^2(b^2 - a^2)^2}{8mc^2a^2}$ (d) $\frac{eH^2b\sqrt{(b^2 - a^2)}}{8mc^2}$

4. If $y(x)$ satisfies

$$\frac{dy}{dx} = y \left[1 + (\log y)^2 \right]$$

and $y(0) = 1$ for $x \geq 0$, then $y\left(\frac{\pi}{2}\right)$ is

- (a) 0 (b) 1 (c) $\frac{\pi}{2}$ (d) infinity

5. Consider two coupled harmonic oscillators of mass m each. The Hamiltonian describing the oscillators is

$$\hat{H} = \frac{\hat{p}_1^2}{2m} + \frac{\hat{p}_2^2}{2m} + \frac{1}{2}m\omega^2 \left(\hat{x}_1^2 + \hat{x}_2^2 + (\hat{x}_1 - \hat{x}_2)^2 \right)$$

The eigenvalues of \hat{H} are given by (with n_1 and n_2 being non-negative integers)

- (a) $E_{n_1, n_2} = \hbar\omega(n_1 + n_2 + 1)$ (b) $E_{n_1, n_2} = \hbar\omega\left(n_1 + \frac{1}{2}\right) + \frac{1}{\sqrt{3}}\hbar\omega\left(n_2 + \frac{1}{2}\right)$
 (c) $E_{n_1, n_2} = \hbar\omega\left(n_1 + \frac{1}{2}\right) + \sqrt{3}\hbar\omega\left(n_2 + \frac{1}{2}\right)$ (d) $E_{n_1, n_2} = \frac{1}{\sqrt{3}}\hbar\omega(n_1 + n_2 + 1)$

6. Consider the Lagrangian, $L = 1 - \sqrt{1 - \dot{q}^2} - \frac{q^2}{2}$

of a particle executing oscillations whose amplitude is A . If p denotes the momentum of the particle, then $4p^2$ is

- (a) $(A^2 - q^2)(4 + A^2 - q^2)$ (b) $(A^2 + q^2)(4 + A^2 - q^2)$
 (c) $(A^2 - q^2)(4 + A^2 + q^2)$ (d) $(A^2 + q^2)(4 + A^2 + q^2)$

7. A block of mass M rests on a plane inclined at an angle θ with respect to the horizontal. A horizontal force $F = Mg$ is applied to the block. If μ is the static friction between the block and the plane, the range of θ so that the block remains stationary is

- (a) $-\mu \leq \tan \theta \leq \mu$ (b) $1 - \mu \leq \cot \theta \leq 1 + \mu$
 (c) $\frac{1 - \mu}{1 + \mu} \leq \tan \theta \leq \frac{1 + \mu}{1 - \mu}$ (d) $\frac{1 - \mu}{1 + \mu} \leq \cot \theta \leq \frac{1 + \mu}{1 - \mu}$

8. A ball comes in from the left with speed 1 (in arbitrary units) and causes a series of collisions. The other four balls shown in the figure are initially at rest. The initial motion is shown below (the number in the circle indicate the object's relative mass). This initial velocities of the balls shown in the figure are represented as $[1, 0, 0, 0, 0]$ A negative sign means that the velocity is directed to the left. All collisions are elastic. Which of the following indicates the velocities of the balls after all the collisions are completed?



- (a) $[-1/2, -1/2, 0, 0, 1/2]$ (b) $[-1/3, 0, 0, 0, 2/3]$
 (c) $[-1/2, 0, 0, 0, 3/4]$ (d) $[-1/2, 0, 0, 0, 1/2]$
9. A large cylinder of radius R filled with particles of mass m . The cylinder spins about its axis at an angular speed ω radians per second, providing an acceleration g for the particle at the rim. If the temperature T is constant inside the cylinder, what is the ratio of air pressure P_0 at the axis to the pressure P_c at the rim?

(a) $\exp\left[\frac{mgR}{2k_bT}\right]$ (b) $\exp\left[-\frac{mgR}{2k_bT}\right]$ (c) $\frac{mgR}{2k_bT}$ (d) $\frac{2k_bT}{mgR}$

10. The coordinate q and the momentum p of a particle satisfy

$$\frac{dq}{dt} = p, \quad \frac{dp}{dt} = -3q - 4p$$

If $A(t)$ is the area of any region of points moving in the (q, p) -space, then the ratio $A(t)/A(0)$ is

- (a) 1 (b) $\exp(-3t)$ (c) $\exp(-4t)$ (d) $\exp(-3t/4)$
11. An ideal fluid is subjected to a thermodynamic process described by $\rho = CV^{-\alpha}$ and $P = n\rho^\Gamma$, where ρ is energy density and P is pressure. For what values of n and Γ , the process is adiabatic if the volume is changed slowly?
- (a) $\Gamma = \alpha - 1, n = 1$ (b) $\Gamma = 1 - \alpha, n = \alpha$ (c) $\Gamma = 1, n = \alpha - 1$ (d) $\Gamma = \alpha, n = 1 - \alpha$

12. If $F(x, y) = x^2 + y^2 + xy$, its Legendre transformed function $G(u, v)$, upto a multiplicative constant, is

(a) $u^2 + v^2 + uv$ (b) $u^2 + v^2 - uv$ (c) $u^2 + v^2$ (d) $(u + v)^2$

13. The elastic wave on a stretched rectangular membrane of size $L \times 2L$ in the x - y plane is described by the function

$$A \sin \frac{\pi x}{L} \sin \frac{\pi y}{L} \cos(\omega t + \phi)$$

where A and ϕ are constants. The speed of the elastic waves is v . The angular frequency ω is

(a) $\frac{\sqrt{5} \pi v}{L}$ (b) $\frac{\sqrt{2} \pi v}{L}$ (c) $\frac{\sqrt{5} \pi v}{2L}$ (d) $\frac{\sqrt{17} \pi v}{2L}$

14. Consider the wavepacket defined by

$$\psi(x) = \int_{-\infty}^{\infty} dk f(k) \exp[i(kx)]$$

Further, $f(k) = 0$ for $|k| > K/2$ and $f(k) = a$ for $|k| \leq K/2$. Then, the form of normalized $\psi(x)$ is

(a) $\frac{\sqrt{8\pi k}}{x} \sin \frac{Kx}{2}$ (b) $\sqrt{\frac{2}{\pi K}} \frac{\sin \frac{Kx}{2}}{x}$ (c) $\frac{\sqrt{8\pi K}}{x} \cos \frac{Kx}{2}$ (d) $\sqrt{\frac{2}{\pi K}} \frac{\sin \frac{Kx}{2}}{x}$



15. In an experiment, certain quantity of an ideal gas at temperature T_0 , pressure P_0 and volume V_0 is heated by a current flowing through a wire for a duration of t seconds. The volume is kept constant and the pressure changes to P_1 . If the experiment is performed at constant pressure starting with the same initial conditions, the volume changes from V_0 to V_1 . The ratio of the specific heats at constant pressure and constant volume is

(a) $\frac{P_1 - P_0}{V_1 - V_0} \frac{V_0}{P_0}$ (b) $\frac{P_1 - P_0}{V_1 - V_0} \frac{V_1}{P_1}$ (c) $\frac{P_1 V_1}{P_0 V_0}$ (d) $\frac{P_0 V_0}{P_1 V_1}$

